

INFILL PANEL HEAD DETAIL

- ① Permarock Sealing Tape SEA/TP610/3-6 for joint width 3-6mm or SEA/TP610/5-12 for joint width 5-12mm
- ② Proprietary mastic sealant (by others)
- ③ Permarock Render Stop Bead STP/06SS (Stainless steel) bedded into reinforcement layer and fully scrimmed in with Permarock Reinforcement Mesh (min 100 mm wide) and Permarock bedding Mortar
- ④ Permarock uPVC finishing bead BEA/LW-66-2 for thin coat render-finishes
- ⑤ Permarock Bedding Mortar incorporating Permarock Reinforcing Mesh
- ⑥ Permarock Decorative Finish
- ⑦ Permarock Insulation (type and thickness to specification) on Permarock Lamella Adhesive or Permarock HP Adhesive (100% coverage)
- ⑧ New metal sill flashing (by others)
- ⑨ Structural opening

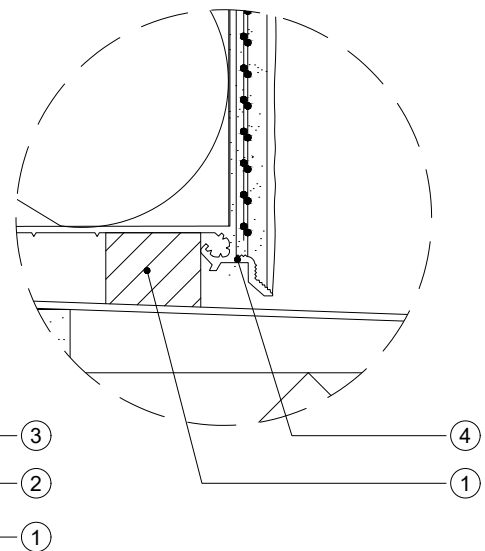
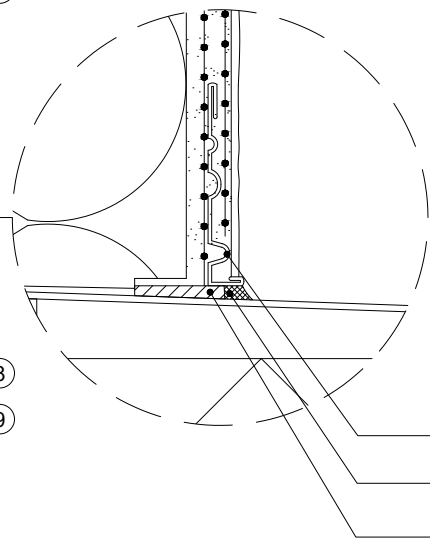
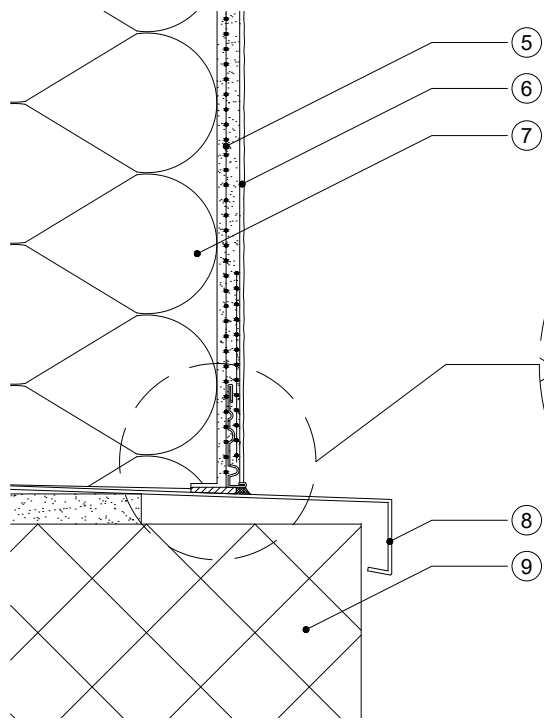

Option One

Option Two

Permarock Render Stop Bead STP/06SS (Stainless steel) bedded into reinforcement layer and fully scrimmed in with Permarock Reinforcement Mesh (min 100 mm wide) and Permarock bedding Mortar

Permarock uPVC finishing bead BEA/LW-66-2 for thin coat render-finishes

INFILL PANEL SILL DETAIL

Permarock Products Ltd.
Jubilee Drive
Loughborough
Leicestershire
LE11 5TW
Tel: (01509) 262924
Email: permarock@permarock.com
Web: www.permarock.com

Client : -	Title : Infill Panel - Sill and Head Details					Drawn By : HN	Approved By : JFR
Project : Standard Detail	Project Ref : -					Scale : NTS	Date : 12/10/2023
Notes :	Rev	Date	Amendments	By	Approved	Original Size : A4	Rev.1
	1	25/11/24	HP Adhesive	HN	JFR		

Where applicable all dimensions and details should be read in conjunction with specialist consultants drawings and the project specification. All dimensions should be checked on site by the contractor and any discrepancies should be brought to the attention of Permarock Products Ltd.
This drawing is the copyright of Permarock Products Ltd. It shall not be copied to any other third party without the express written consent of Permarock Products Ltd.
DISCLAIMER: Whilst this information/document/proposal (together "Information") is based on the latest manufacturer facts and findings of which we are aware, we are not engaged as a designer or other contractor in respect of your project and so the Information is general in nature and we cannot guarantee that any Information provided meets all of your specific project requirements. Given this, we cannot guarantee that any products selected, specified and/or purchased by you and their proposed applications are fit for the intended purpose. Any specification or purchase by you is at your own risk and we recommend the Information be reviewed and approved by an appropriately qualified professional prior to specification or purchase. Without prejudice to the generality of the foregoing you (or the appropriately qualified professional from whom you seek advice) shall ensure that any performance criteria and/or coverage rates quoted can be achieved in each instance when compiling or pricing specific projects. To the extent permitted by law, Permarock will not be liable (whether in contract, tort (including negligence), breach of duty, misrepresentation or otherwise) for any loss or liability (of whatsoever kind) arising out of or in connection with any Information we may provide.